

PolyGard® Transmitter ADT23-34XX for combustible gases

DESCRIPTION

ADT transmitter with digital processing of the measured values and temperature compensation for the continuous monitoring of the ambient air and detection of combustible gases and vapours. The calibration routine with selective access release enables the comfortable calibration of the transmitter. In addition to the standard analog output (0) 4-20 mA or (0) 2- 10 V DC the ADT-23 is equipped with a RS-485 interface for different protocols. Two relays with adjustable switch threshold are available as an option.

APPLICATION

The transmitter is used within a wide commercial range for detecting flammable gases and vapours. Due to the output signal and the RS-485 interface the transmitter ADT-23 is compatible to the PolyGard gas controller series MGC and DGC by MSR-E as well as to any other electronic control or automation system.

FEATURES

- Digital processing of the measured values including temperature compensation
- Continuous monitoring
- Low zero-point drift
- Good poisoning permanence
- Long life sensor
- Modular design (plug-in)
- Simple maintenance
- Comfortable calibration with selective access release
- Reverse polarity protected, overload protected and short-circuit proof
- (0) 4 – 20 mA / (0) 2 – 10 V analog signal output, selectable
- Serial interface RS-485
- IP65 protected
- Manual calibration via potentiometer (optional)
- Manual addressing at RS-485 mode (optional)
- 4 – 20mA analog input for external transmitter (optional)
- Approved according to EN 61010-1; ANSI/UL 61010 1; CAN/CSA-C22.2 No. 61010-1
- Relay output (optional)
- Integrated buzzer (optional)
- LED flashlight (optional)
- LCD display (optional)
- LED status display (optional)
- Heating (optional)
- Duct mounting (optional)



Standard enclosure



SPECIFICATIONS

Sensor Performance

Gas type	Combustible gases/ vapours (see order inform.)
Sensor element	Ex sensor, catalytic bead (pellistor)
Measuring range	0 - 100% LEL
Accuracy	± 1 % of reading
Long-term zero point drift	< ± 6 % measuring range /year
Long-term sensitivity drift	< ± 1.5 % measuring range / month
Response time	t ₅₀ ≤ 3 s; t ₉₀ ≤ 10 s /methane
Sensor life expectancy	3 years/normal operating environment
Temperature range	- 20 °C to + 50 °C (-4 °F to 122 °F) w/o heating
Temperature drift	≤ 1%
Humidity range	5 – 95 % RH non-condensing
Pressure range	Atmospheric ± 20 %
Storage temperature	5 °C to 30 °C (41 °F to 86 °F)
Storage period	Max. 6 months
Mounting height	Depending on gas type

Electrical

Power supply	16 - 28 VDC/AC, reverse polarity protected
Power consumption (without options)	35 mA, max. (0.85 VA)

Output Signal

Analog output signal	(0) 4 – 20 mA, load ≤ 500 Ω
Selectable: Current / voltage	(0) 2 - 10 V; load ≥ 50 k Ω
Starting point 0 / 20 %	proportional, overload and short-circuit protected

Serial Interface

Transceiver	RS 485 / 19200 Baud (9600 for Mod-Bus)
-------------	--

Physical Characteristics

Enclosure Plastic Type A*	Polycarbonate
Flammability	UL 94 V2
Enclosure color*	RAL 7032 (light grey)
Dimensions (W x H x D)	94 x 130 x 57 mm (3.7 x 5.12 x 2.24 inch.)
Weight	Approx. 0.5 kg (1.1 lbs.)
Protection class	IP 65
Installation	Wall mounting
Cable entry	Standard 1 x M 20
Wire connection	Screw type terminal, min. 0.25 mm ² (24 AWG) max. 2.5 mm ² (14 AWG)
Wire distance	Current signal ca. 500 m (1500 ft.) Voltage signal ca. 200 m (600 ft.)

Guidelines

EMC Directives 2004/108/EC
EN 61010-1:2010
ANSI/UL 61010-1
CAN/CSA-C22.2 No. 61010-1
CE

Warranty

1 year on material (without sensor)

* For further enclosure types see datasheet ADT Enclosure.

GAS ALARM SYSTEMS

Options

Relay Output

Alarm relay 1	30 VAC/DC 0.5 A, potential-free, SPDT
Alarm relay 2	30 VAC/DC 0.5 A, potential-free, SPNO/SPNC
Power consumption	30 mA, max. (0.8 VA)

Warning Buzzer

Acoustic pressure	85 dB (distance 300 mm) (1 ft.)
Frequency	3.5 kHz
Power consumption	30 mA, max. (0.8 VA)

LCD Display

LCD	Two lines, 16 characters each
Power consumption	10 mA, max. (0.3 VA)

LED Display

Green-yellow-red	Supply, low alarm, high alarm
Power consumption	10 mA, (max. 0.3 VA)

Heating

Temperature controlled	3 °C ±2°C (37.4°F ± 3.6°F)
Ambient temperature	- 40 °C (-40°F)
Power consumption	0.3 A; (7.5 VA)

Analog Input

Only for RS 485 mode	4 – 20 mA overload and short-circuit protected, input resistance 200 Ω
Tension for ext. analog transmitter	24 VDC max. load 50 mA

CONNECTING DIAGRAM

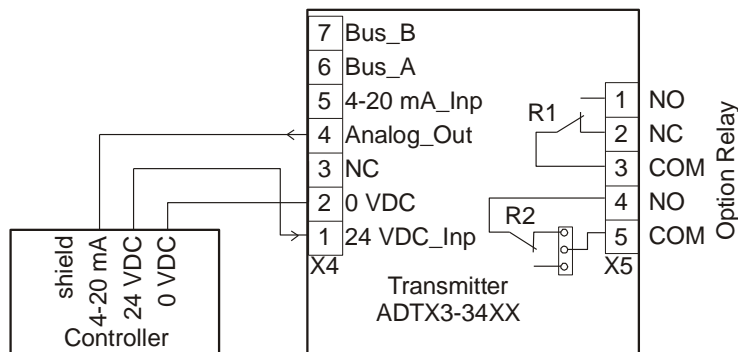

ORDERING INFORMATION

ADT-23-34XX-X-XXXXXXXXXX

Options

1XXXXXXXX	Relay output ²
X1XXXXXXXX	Warning buzzer int.
X2XXXXXXXX	Flashlight (LED)
X3XXXXXXXX	Warning buzzer and flashlight
XX1XXXXXXXX	Heating
XXXX1XXXX	RS- 485 protocol for DGC-05 series
XXXX2XXXX	RS- 485 protocol ModBUS
XXXX3XXXX	RS- 485 protocol customer-specific
XXXXX1XXX	Tool calibration / addressing mode
XXXXX2XXX	Manual calibration
XXXXX3XXX	Manual addressing
XXXXX4XXX	Manual calibration / addressing
XXXXXX1XX	LCD display ³
XXXXXX2XX	LED status display ^{2,3}
XXXXXXX1X	4 – 20 mA analog input
XXXXXXXX1	Factory calibration 0 - 100 % LEL

Enclosure¹

A	Plastic enclosure
B	Duct mounting
5	Stainless steel

Gas types

00	Methane	CH ₄
08	Ammonia	NH ₃
10	Ethylene	C ₂ H ₄
25	Ethyl alcohol	C ₂ H ₅ OH
27	Ethyl acetate	CH ₃ COOC ₂ H ₅
30	Benzene	C ₆ H ₆
35	n-Hexane	C ₆ H ₁₄
40	Hydrogen	H ₂
45	Iso propanol alcohol	(CH ₃) ₂ CHOH
50	Methanol	CH ₃ OH
58	Methyl ethyl ketone	C ₄ H ₈ O
60	n-Butane	C ₄ H ₁₀
68	Iso butanol	C ₄ H ₁₀ O
70	n-Octane	C ₈ H ₁₈
75	n-Pentane	C ₅ H ₁₂
80	Propane (LPG)	C ₃ H ₈
85	Acetone	(CH ₃) ₂ CO
90	Toluene	C ₇ H ₈
91	n-Heptane	C ₇ H ₁₆
98	JP8	

¹ See Data sheet "PolyGard ADT Enclosure"

² Please indicate thresholds for low and high alarm when ordering.

³ Not in connection with stainless steel housing, not in connection with option Relay or RS-485 interface

Example: Ex transmitter for propane gas, stainless steel housing, tool mode, 0- 100 % LEL, factory calibration.

Ordering number: ADT-23-3480-5-000001001